

HEAVY HINGE™



Features

- Perfect for Folding Gates
- Proven in Heavy, Outdoor, Heavy-use Vehicle Gate Applications
- Clean, Unobtrusive Aesthetics
- Extra Quiet
- Easy Attachment/Remove Without Welding or Grinding the Hinge
- Low Maintenance with Convenient Zirc Fitting



TORXUN HEAVY HINGE™

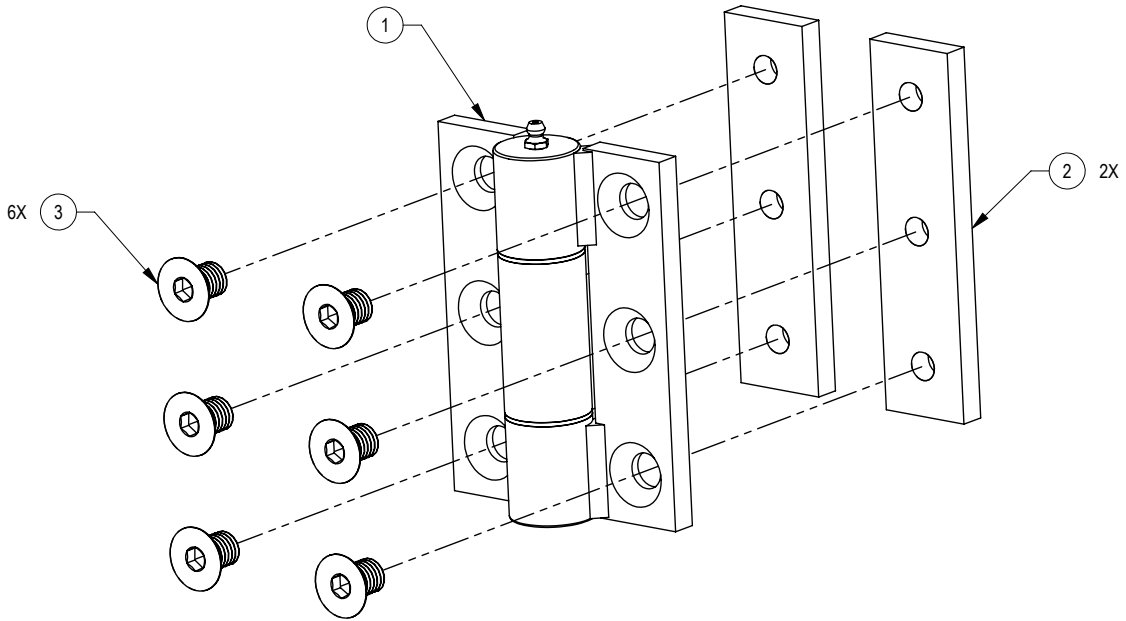

Technical Data

Facility	Data
Weight	4.5 lbs
Material	Carbon Steel, Stainless Steel Pin, Bronze Bushing
Dimensions	5.5" high x 4" wide x 1-3/4" deep
Weight rating	estimated 5,000 lbs each

Product	Part #
QuickFold Hinge Assembly	9906.011R
Gate Mounting Weld Plate Only - For Replacment	9906-0082
Hinge without Gate Mounting Weld Plate	9906-008R

3-year warranty

About TORXUN

TORXUN engineers architectural-grade products for vehicle access controlled systems. Everything is produced in Tracy, California.



50 Sloan Court, Tracy, CA 95304
(888) 491-4283



Precision Handcrafted
in Northern California
from U.S. Steel.